

THE REPRODUCTION, DISTRIBUTION AND UTILIZATION OF THIS DOCUMENT, AS WELL AS THE COMMUNICATION OF ITS CONTENTS TO OTHERS WITHOUT EXPLICIT AUTHORIZATION IS PROHIBITED. OFFENDERS WILL BE HELD LIABLE FOR THE PAYMENT OF DAMAGES. ALL RIGHTS RESERVED IN THE EVENT OF THE GRANT OF A PATENT, UTILITY MODEL OR DESIGN. (PER ISO 15016)

REVISIONS			
REV	DESCRIPTION	DATE	APPROVED
A	INITIAL RELEASE SUPERSEDES PRE-PRODUCTION DRAWING FJ5985-1212S REV "NONE" (1) ADDED "(2 REQUIRED)" (2) 1 1/16-14 TH'D WAS 1 1/6-14 TH'D	1999-08-12	EN-F19170 DP-1256 JJB

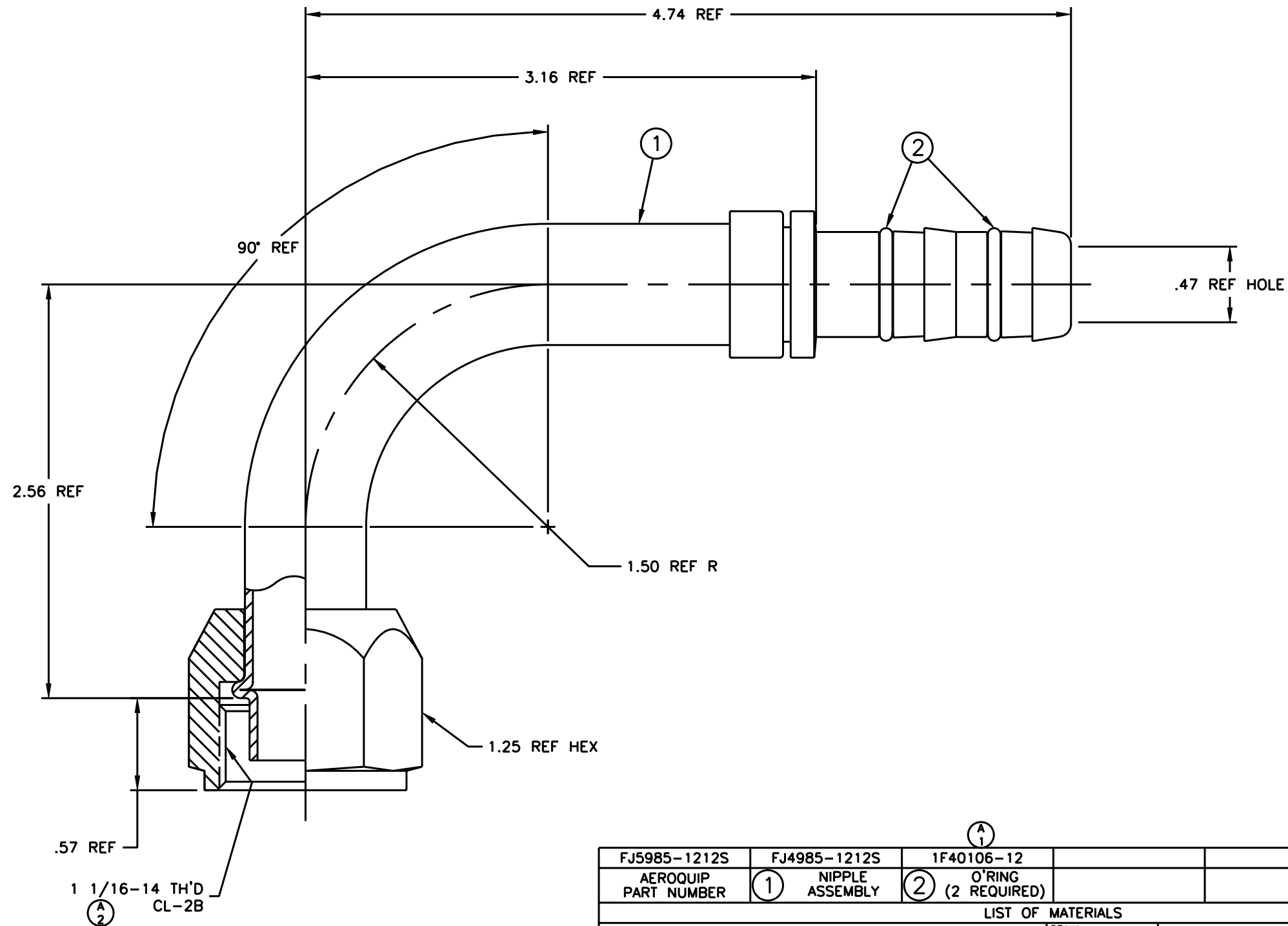

1. PROCESS AS FOLLOWS:
(a) LUBRICATE O'RINGS AND ASSEMBLE ON NIPPLE AS SHOWN.

ITEM NO.	MATERIAL	QTY	DESCRIPTION
1	STEEL	1	NIPPLE ASSEMBLY
2	HNBR	2	O-RING

FJ5985-1212S AEROQUIP PART NUMBER	FJ4985-1212S NIPPLE ASSEMBLY	1F40106-12 O-RING (2 REQUIRED)
---	------------------------------------	--------------------------------------

DRAWN T. HARTFORD CHECKED J. BAHNSEN APPROVED J. GRAU RELEASE DATE 1999-08-25 EN-F19170 DP-1256 THIRD ANGLE PROJECTION ITEM TYPE: DTZA	FLUID CONVEYANCE DIVISION DRAWING TITLE FITTING ASSEMBLY 90°, FEMALE O-RING PILOT (SHORT), GH134 HOSE SIZE A2 DRAWING NUMBER FJ5985-1212S SCALE 2/1 DIST U CAGE CODE 01276 SHEET NO *
---	--

INCH

REV. A
 SH. *
 Dwg. No. FJ5985-1212S

