

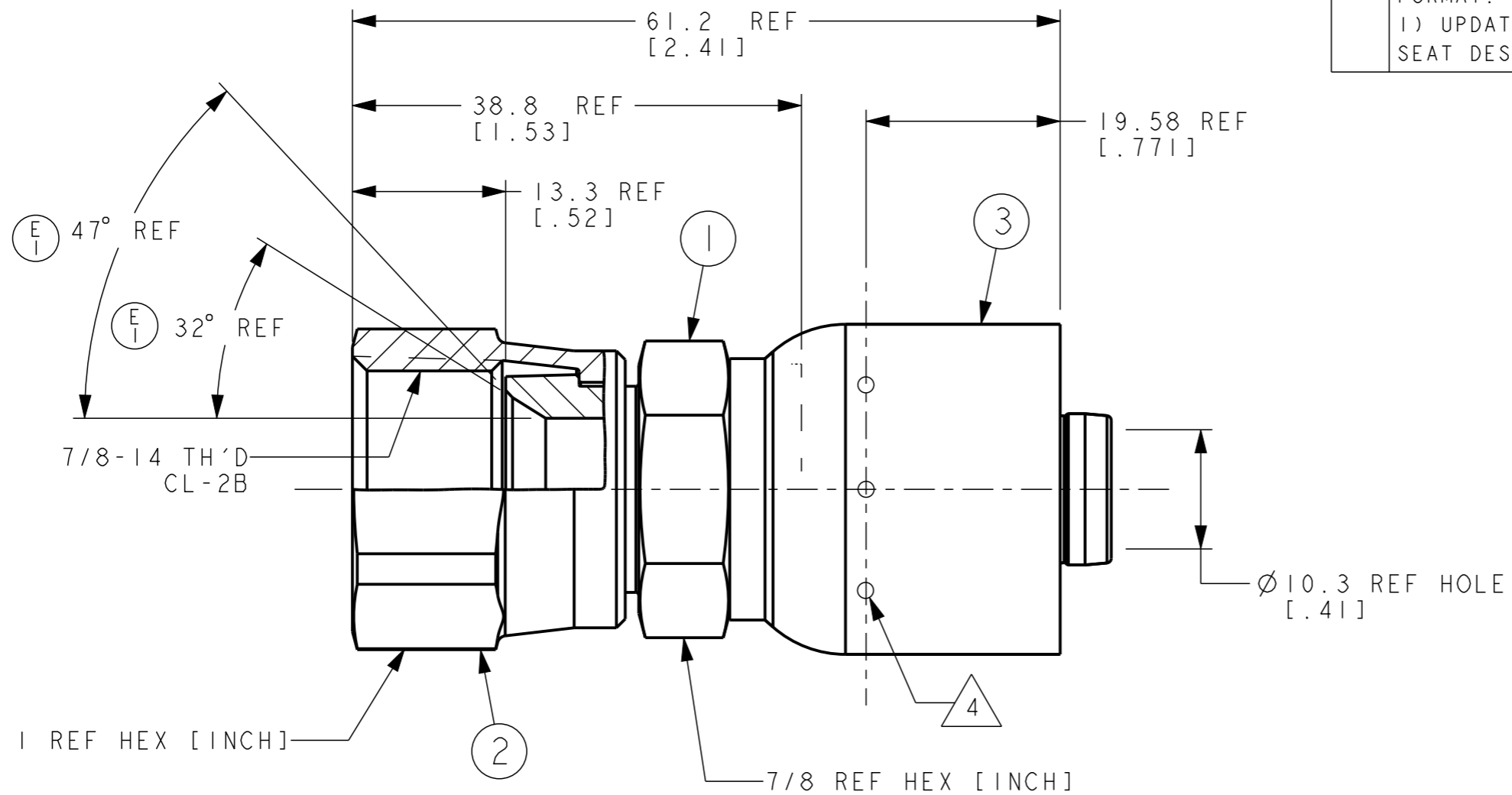

REVISIONS			
REV	DESCRIPTION	DATE	APPROVED
E	REDRAWN. UPDATED TO DANFOSS FORMAT. 1) UPDATED NIPPLE TO DUAL SEAT DESIGN.	2023-04-10 TMH	CO-0228925



METRIC

FJ3114-1010S	FW1231-1010S	210204-10S	FW1186-10S		
PART NUMBER	① NIPPLE	② NUT	③ SOCKET		

LIST OF MATERIALS

ITEM NO.	MATERIAL	FLUID CONVEYANCE DIVISION MAUMEE, OHIO U.S.A.		DRAWN	T. HIRVE
1	STEEL			CHECKED	T. HIRVE
2	STEEL			APPROVED	A. CHIKKABAGEWADI
3	STEEL			RELEASE DATE	2023-04-10
				DRAWING INTERPRETATION PER ES 10	
				DRAWING TITLE	
				FITTING ASSEMBLY	
				HIGH PRESSURE SAE 37° FEMALE SWIVEL 1503 HOSE	
		CO-0228925	CAGE CODE 01276	DRAWING NUMBER	
		THIRD ANGLE PROJECTION	DIST U	FJ3114-1010S	
		SIZE A3	SCALE 2/1	REV	
		SHEET 1		E	

④ CRIMP LOCATION IMPRESSION MARK (6-8 PLACES).

3. THESE SHOULD BE NO SOCKET MOVEMENT ON THE NIPPLE AFTER CRIMPING.

2. PROCESS AS FOLLOWS:
(a) CRIMP NUT PER ACES 2813.
(b) CRIMP SOCKET PER ES 2409P17.

1. DIMENSIONS ARE IN MILLIMETERS [INCHES].

THE REPRODUCTION, DISTRIBUTION, AND UTILIZATION OF THIS DOCUMENT AS WELL AS THE COMMUNICATION OF ITS CONTENTS TO OTHERS WITHOUT EXPLICIT AUTHORIZATION IS PROHIBITED. OFFENDERS WILL BE HELD LIABLE FOR THE PAYMENT OF DAMAGES. ALL RIGHTS RESERVED IN THE EVENT OF THE GRANT OF A PATENT, UTILITY MODEL OR DESIGN. (PER ISO 16016)