

PART NUMBER	SOCKET	SURFACE AREA	MASS	"L" REF
IGA12FRI2	IF21-12-S	24692 mm ²	240 g	69.6 [2.74]
IGA12FRI2	IG12	24124 mm ²	245 g	67.3 [2.65]

REVISIONS			
REV	DESCRIPTION	DATE	APPROVED
C	REDRAWN AND REDESIGNED. 1) ADDED HVF DESIGN 2) ADDED NOTE #2. 3) UPDATED DRAWING VIEW GEOMETRY TO SHOW HVF DESIGN.	2023-02-17 VSP	CO-0227977

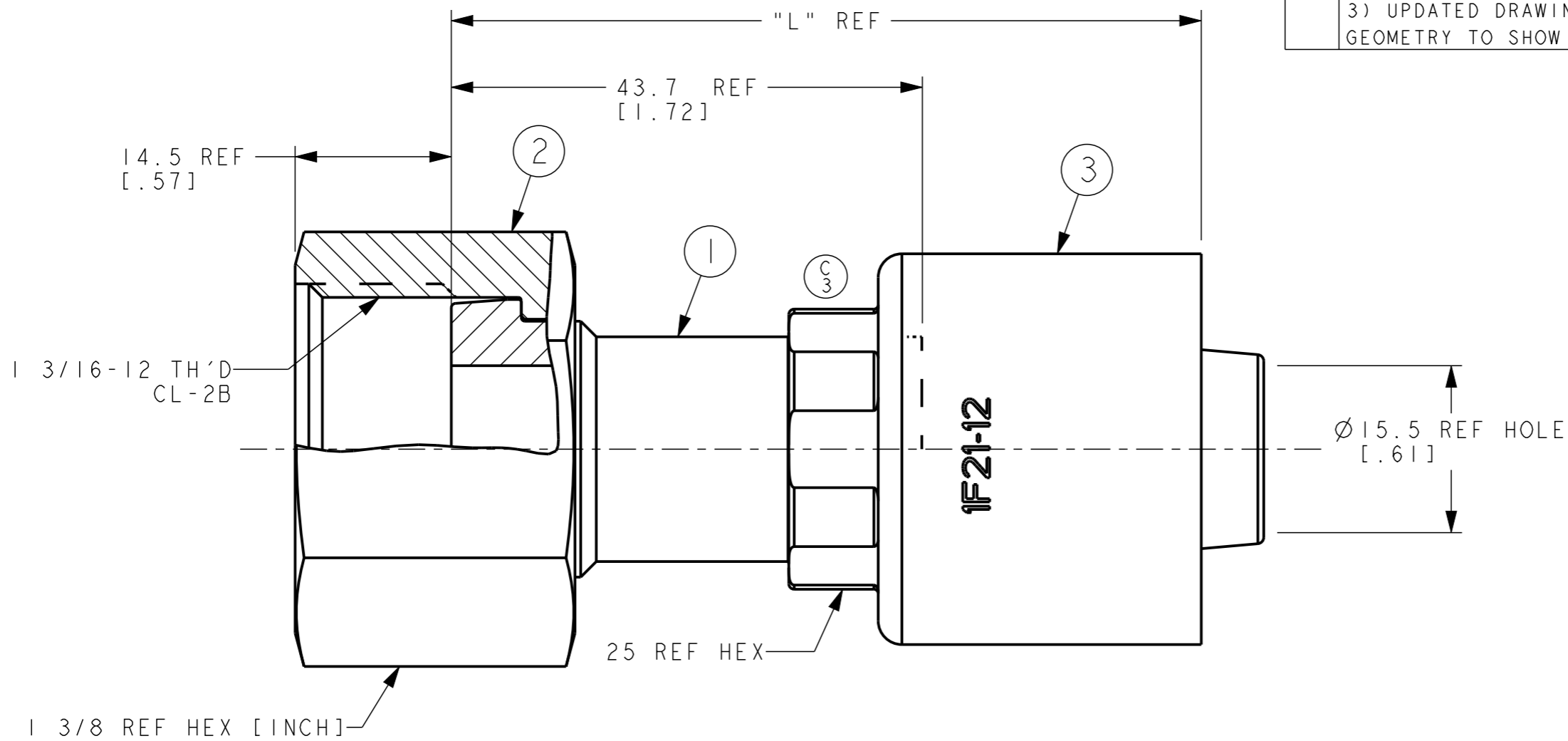

△4	△3	32712E-S72	IGA12FRI2	IF40010A1212-S	FC1473-12S	IG12
⊕1	△2	32712E-S72	IGA12FRI2	IF40611-1212-S	FC2326-12S	IF21-12-S
		WEATHERHEAD PART NUMBER	AEROQUIP PART NUMBER	① NIPPLE	② NUT	③ SOCKET

LIST OF MATERIALS

ITEM NO.	MATERIAL
1	STEEL
2	STEEL
3	STEEL

FLUID CONVEYANCE DIVISION
MAUMEE, OHIO U.S.A.

Danfoss

CO-0227977 CAGE CODE 01276

THIRD ANGLE PROJECTION

SIZE	A3
SCALE	2/1
SHEET	1

DRAWN V. PATIL
CHECKED V. PATIL
APPROVED N. BEINING
RELEASE DATE 2023-02-17
DRAWING INTERPRETATION PER ES 10
DRAWING TITLE
FITTING ASSEMBLY
ORS FEMALE SWIVEL
OTC

DRAWING NUMBER	IGA12FRI2	REV	C
----------------	-----------	-----	---

THE REPRODUCTION, DISTRIBUTION, AND UTILIZATION OF THIS DOCUMENT AS WELL AS THE COMMUNICATION OF ITS CONTENTS TO OTHERS WITHOUT EXPLICIT AUTHORIZATION IS PROHIBITED. OFFENDERS WILL BE HELD LIABLE FOR THE PAYMENT OF DAMAGES. ALL RIGHTS RESERVED IN THE EVENT OF THE GRANT OF A PATENT, UTILITY MODEL OR DESIGN. (PER ISO 16016)

- △4 ISAI2FRI2 NIPPLE ASSEMBLY MAY BE SUBSTITUTED FOR ITEMS #1 AND #2.
 - △3 PROCESS AS FOLLOWS:
a) CRIMP NUT PER ES 2409PI.
b) ASSEMBLE SOCKET PER ACES 2813.
 - △2 PROCESS AS FOLLOWS:
a) ASSEMBLE NUT.
b) CRIMP SOCKET PER ACES 2813. ⊕2
1. DIMENSIONS ARE IN MILLIMETERS [INCHES].