

THE REPRODUCTION, DISTRIBUTION AND UTILIZATION OF THIS DOCUMENT AS WELL AS THE COMMUNICATION OF ITS CONTENTS TO OTHERS WITHOUT EXPLICIT AUTHORIZATION IS PROHIBITED. OFFENDERS WILL BE HELD LIABLE FOR THE PAYMENT OF DAMAGES. ALL RIGHTS RESERVED IN THE EVENT OF THE GRANT OF A PATENT, UTILITY MODEL OR DESIGN. (PER ISO 18018)

REVISIONS

REV	DESCRIPTION	DATE	APPROVED
B	REDRAWN - SUPERSEDES 1G_FL SHEET 2 REV. A* FOR 1G16FL20	12-13-95	EN-F16139 DP-24900

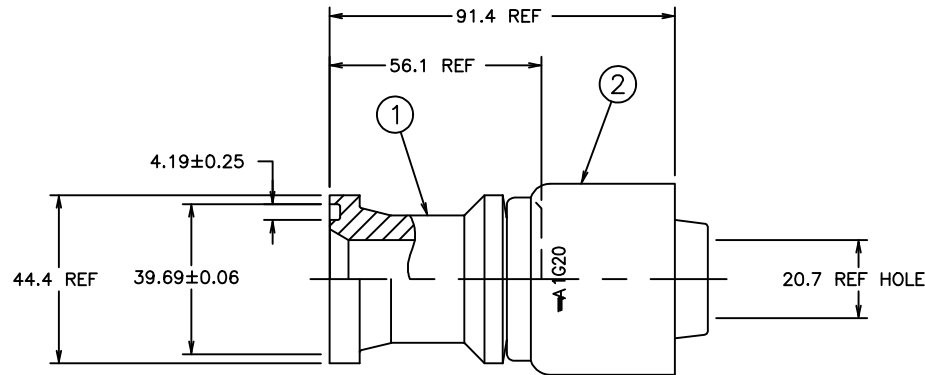

91.4	3.60
56.1	2.21
44.4	1.75
39.69±0.06	1.5625±.0025
39.6	1.56
33.3	1.31
20.7	.81
4.19±0.25	.165±.010
3	.12
MM	INCH

CONVERSION

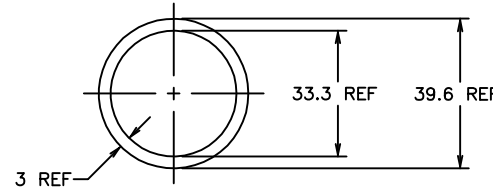

△ O'RING DETAIL

METRIC

1G16FL20	1S16FL20	1G20			
AEROQUIP PART NUMBER	① NIPPLE	② SOCKET			
LIST OF MATERIALS					
ITEM NO.	MATERIAL	DRAWN R.D.GARRETT	FLUID CONVEYANCE DIVISION DRAWING TITLE FITTING ASSEMBLY SPLIT FLANGE TYPE (CODE 61), OTC		
1	STEEL	CHECKED M.MOLINA			
2	STEEL	APPROVED R.D.GARRETT			
		RELEASE DATE 12-18-95			
		EN-F16139 DP-24900	SIZE C	DRAWING NUMBER 1G16FL20	REV B
		THIRD ANGLE PROJECTION	SCALE 1/1	DIST U	CAGE CODE 01276 SHEET NO

△ O'RING SHOWN FOR REFERENCE ONLY. SUPPLIED BUT NOT FURNISHED WITH ASSEMBLY.

1. ASSEMBLE SOCKET PER ACES 2813.

DWG. NO. 1G16FL20 SH. B

CONVERTED DRAWING CADAM to AutoCAD 18/98